



4X4 ACCESSORIES



**DATE:**

October 2014

**DESCRIPTION:**

ARB Recovery Point

**APPLICATION:**

Toyota Prado 150 & FJ Cruiser

**PART NO. & BARCODE:**

2821020 - 9332018035172  
Recovery Point Prado 150 |LHS  
2821030 - 9332018035189  
Recovery Point Prado 150|RHS

**PRODUCT GROUP:**

004 - ARB Recovery Points

**FITTING:**

See Table Page 2

**AVAILABILITY DATE:**

In Stock



# PRODUCT SPECIFICATION

## DESIGN & DEVELOPMENT:

Designed and tested by ARB's engineers to continue with the "Recovery Train" concept the ARB Recovery Point has been designed and developed for fitment to the Toyota Prado 150 and the Toyota FJ Cruiser. The main section of the recovery point is made from 20mm steel plate strengthened with 6mm steel plate gussets. Both left and right hand fitment recovery points have been developed and are supplied with the necessary mounting hardware.

Left and right hand fitment recovery points have been developed as they are a mirrored design. Fitment of two recovery points have a number of advantages including:

- Access to one point if the other side of the vehicle is buried in mud or unable to be accessed safely
- Ability to pull from the side most suitable for recovery. Different recovery situations may require different set up of recovery equipment to suit either other vehicles involved in the recovery or anchor points available.
- It is important that when recovering a vehicle, the snatch strap should NEVER exceed the maximum turning angle of the front wheels. This can damage the recovery equipment and / or the vehicle in recovery.

As each point is rated at 8,000kg the use of bridle straps is not required. Due to the uneven nature of loads placed on bridle straps it is recommended that they are only used for straight line pulls. It's important to note that the angle of bridle strap loads should never exceed the maximum turning angle of the front wheels and that the load is central on the bridle strap.

A separate recovery point is being developed for the Toyota Prado 120.

## DESIGN & DEVELOPMENT CONT.:

The recovery point is rated in an angled direction of pull for angles up to the maximum turn angle of the front wheels of the vehicle. To ensure that during an angled recovery there are no inappropriate forces exerted on the shackle, the recovery point has a long slot to allow the recommended bow shackle to be fed through and the strap attached via the pin instead of the bow.

This allows even distribution of the recovery force through the shackle to avoid side loads on the pin. Side loads on the pin invoke forces that tend to open up the shackle, putting unwanted load on its weakest point, the pin threads.

ARB's engineers have developed the recovery point to fit in conjunction with standard bumpers and ARB bars and to use points within the chassis to achieve the 8,000kg rating. Four mount points are included per recovery point to ensure that there is no torsional twist on angled pulls. A crush tube and nut plate extension are included in the fitting kit to work with existing mount holes within the chassis.

## FITTING:

The recovery point has been designed to fit either with the factory front bumper fitted or with an ARB bar fitted. Other manufacturers bars have not been test fitted and fitment is not recommended with other bars.

ARB testing has been conducted with the Fastener Torque Settings as per the supplied fitting instructions.

It is recommended that fitting of the recovery points is done at the same time as bar installation.

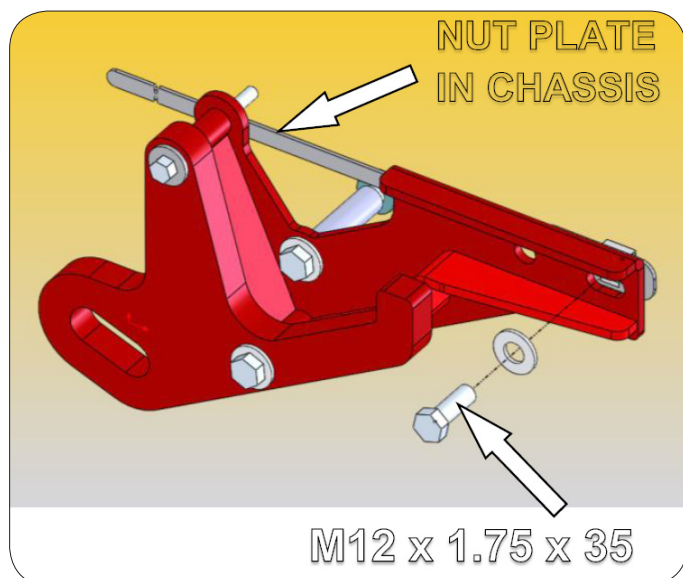

## RECOMMENDED FITTING TIMES:

	Prado 150	FJ Cruiser
In conjunction with ARB bar installation	1 hr per Recovery Point	1 hr per Recovery Point
Standard Vehicle Bumper	1 hr Remove and refit of bumper plus 1 hr per Recovery Point	1 hr Remove and refit of bumper plus 1 hr per Recovery Point
ARB Bar already fitted	2 hr Remove and refit of bar Plus 1 hr per recovery point	2 hr Remove and refit of bar Plus 1 hr per recovery point

## SAFETY:

Each ARB Recovery Point is supplied with an operator instruction card that identifies the correct method of attaching both the shackle and recovery strap as well as important safety information. This card is designed to be kept in the glove compartment of the vehicle.

Recovery points also have a warning label attached which clearly identifies the strap and shackle rating to be used with the point and usage and safety information.

Maximum strap rating is an 8000kg strap. Recommended shackle rating is 4.75t.

